

min. dimensions C-hatch with piano hinge

for cutout heights up to 600mm - without thrust rod

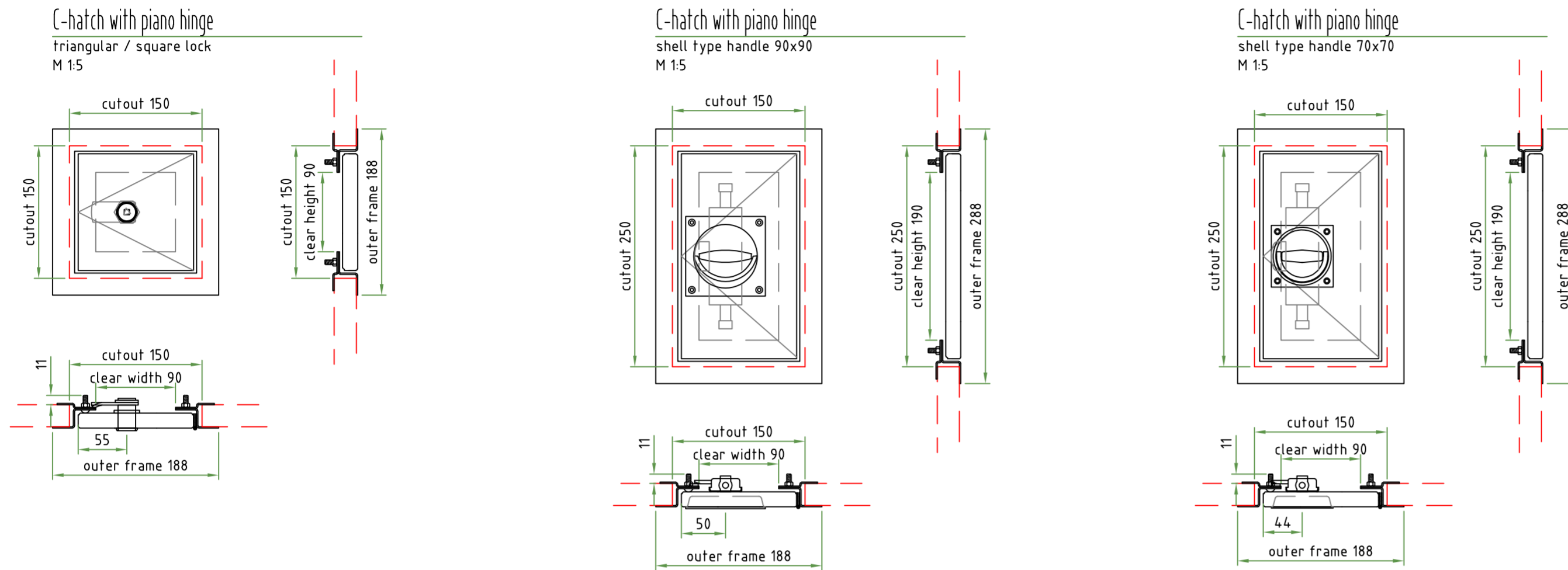

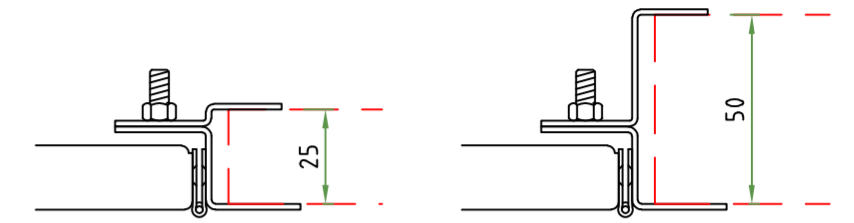

Detail wall thickness

M 1:2

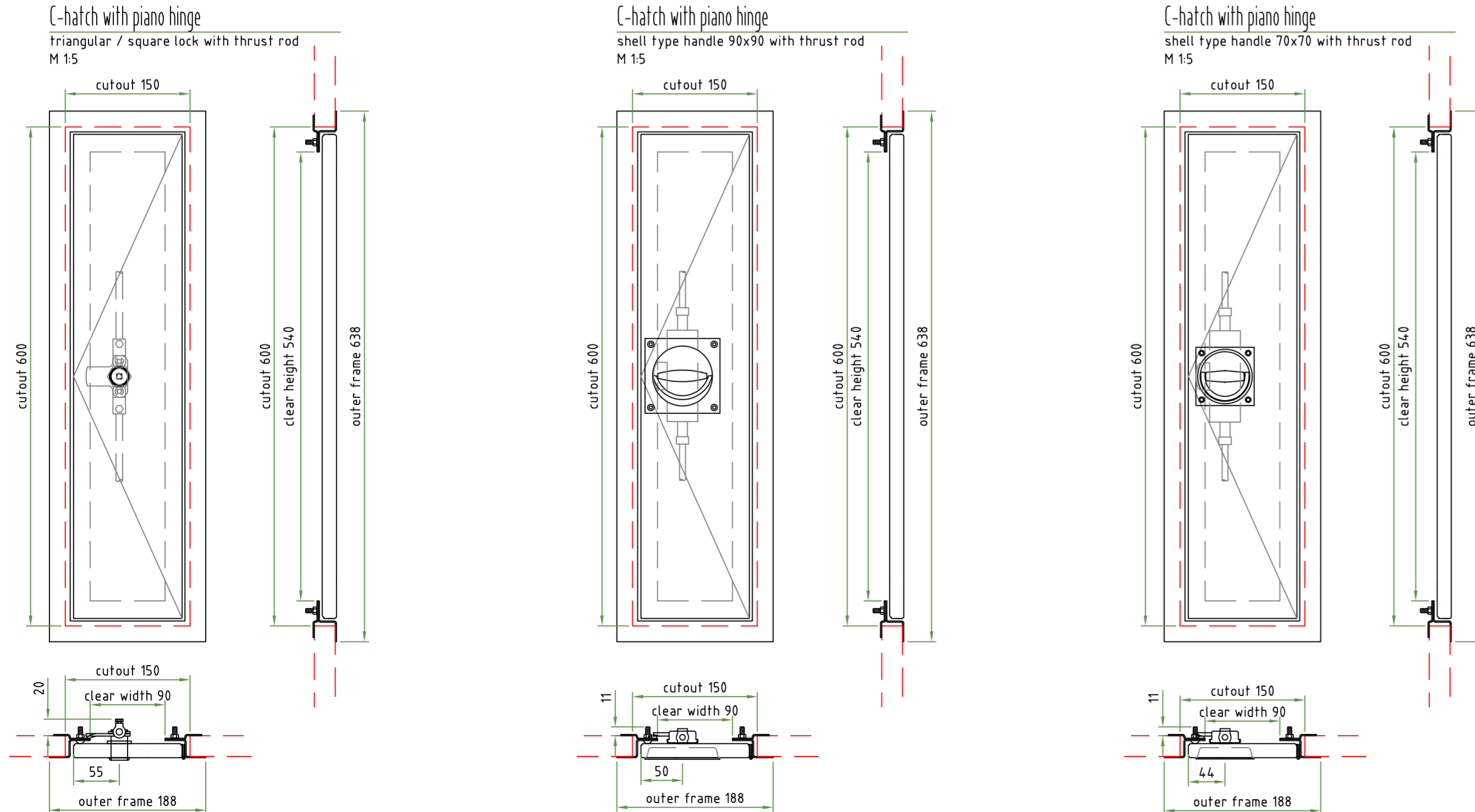

for cutout heights from 600mm and up - with thrust rod



CAD-System:		Tolerance		Scale 1:5		Weight	
				Name and No. of Typ			
08		Date	Name	Title			
07		Draw 17.03.2020	IH	min. dimensions C-hatch with piano hinge			
06		Checked XX.XX.XX	XXXXXX				
05		Stand XX.XX.XX	XXXXXX				
04							
03							
02				Drawing No.			
01				Repl. for			
Rev. No.	Revision	Date	Name	 interior outfitting insulation		Repl. by	